

# Study of the resilience of a composite material intended for the orthopedic prosthesis of a tibia.

N.SASSANE\*, K.BOUBENDIRA, A.BENFOUGHAL, N.BOUGHEDIR, N.HAMZAOUI.

Research Center in Industrial Technologies (CRTI), P.O. Box 64 Cheraga 16014. Algiers. ALGERIA. [n.sasane@crti.dz](mailto:n.sasane@crti.dz)

## Abstract:

*This approach is based on the mechanical characterization of a biomaterial which is an organic composite with a thermosetting polymer matrix reinforced with a glass fiber; this composite has been produced by a conventional casting method. Currently, composite polymer-matrix objects occupy an important place in the aeronautics, automotive, medical industry etc....., for this purpose, we are interested in the study of a mechanical property of a thermosetting polymer matrix composite reinforced with glass fiber, this composite is intended for the orthopedic prosthesis of a tibia, this property called resilience. For so doing, we have realized a Charpy shock test on a sample of the polymer matrix composite reinforced with a glass fiber for the orthopedic prosthesis of a tibia. We have also supported this study by a hardness test and microscopic characterization (SEM) to reveal the microstructure of the composite.*

**Key words:** *composite – mechanical property – resilience –hardness – microstructure.*

## 1. Introduction

Composite materials were logically imperative in certain applications since about forty years because of their specific mechanical properties (brought back to their density) exceptional and of their predisposition in a custom-made conception. Almost 40 years of evolution and innovations have passed, but the innovation conjugates only in the present or in the future [1].

The break of a material it is an irreversible process of modification or change of the microstructure. For composite materials stratify, the mechanisms of damage are mainly the unstickings fiber/matrix, the cross-functional cracks, the die-lamination and finally the breaks of fibers [2].

To validate the use of the polymer materials in the technical applications require specific methods of characterization, in the purpose for example to estimate the capacity of the material to support loads by test of impact this, to determine the absorbed energy, the tore resistance of the material [3].

The behavior of certain very resistant polymers does not behave in a elastic way they considered the case of total plastic deformation, They are and we considered the case of completely plastic deformation. The measure of absorbed energy is verify by the hypothesis of the elastic deformations by this condition one can deduct the impact resistance [4]. **The objective of this work focuses on a mechanical characterization under dynamic loading of a composite material for orthopedic use, consisting of a polymer matrix reinforced with a glass fiber, elaborated by conventional casting. In order to evaluate the impact resistance of the composite as a function of the atmospheric temperature, to do this, five temperatures was used (5 °, 15 °, 25 °, 35 °, 45 °).**

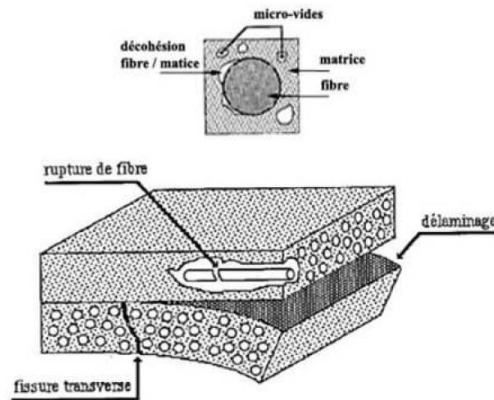

**Figure.1.** *Mechanisms of damage to stratified composites* [2].

## 1. Experimental procedures

### 1.1. Resilience testing

The test in the shock where we also call test of impact strength consists in breaking, by a single shock, a test tube beforehand cut in its environment (middle) and in measuring the energy  $U$  (in joules) absorbed by the break. The impact strength is defined by the letter  $K$ .

The test comes true on a machine called mutton pendulum KARLFRANK type 53580 of an energy of impact of 150 + 300 joules. We measure the impact resistance of the material (KCV) (figure 2).

The specimen used is a specimen of rectangular section 10mm X 55mm, and of Sharp notches as V at mid span of 2mm with a crack to depth ( $a$ ) and with an angle of 45 °.

The "figure 4" shows the broken sample.

The tests are carried out at ambient temperature and also with different temperatures.

Once the impact test is realized, the relevant parameters (impact energy, resilience, compliance, factor GIC) can be deduced as follows:

**a) The impact energy ( $U$ )** was calculated automatically by the Charpy machine.

**b) The resilience ( $K_{cv}$ )** was measured using the following equation:  $K_{CV} = \frac{U}{S}$  (J/cm<sup>2</sup>), where:

$U$ : is the energy absorbed by the break (J) and  $S$ : is the section to the right of the notch (cm<sup>2</sup>).

**c) The Compliance** is the product of three parameters: sample thickness ( $B$ ), width of specimen ( $W$ ) and shape factor ( $\emptyset$ ) the latter calculates as follows:

$\emptyset = \frac{1}{2} \left( \frac{a}{W} \right) + \frac{1}{18\pi} \left( \frac{2L}{W} \right) \frac{1}{(a/w)}$ , we use this equation if the following condition is verified:  $\alpha =$

$\frac{3L}{D}$  and  $\beta = 2 \left( \frac{L}{D} \right)^a$  so that we:  $\beta/2\alpha^2 = L/9D$  [4].

Definition of compliance: is the conformity of the specimen tested; generally, the tests are to demonstrate compliance with a performance specification [5].

**d) Factor GIC:** The fact that there is fragility, there is a linear relationship between the fracture energy and specimens compliance function [3]. So, the factor GIC is the tangent of the average curve for 05 samples of the same material at the same temperature.



Figure.2. Photograph of a Charpy pendulum sheep.

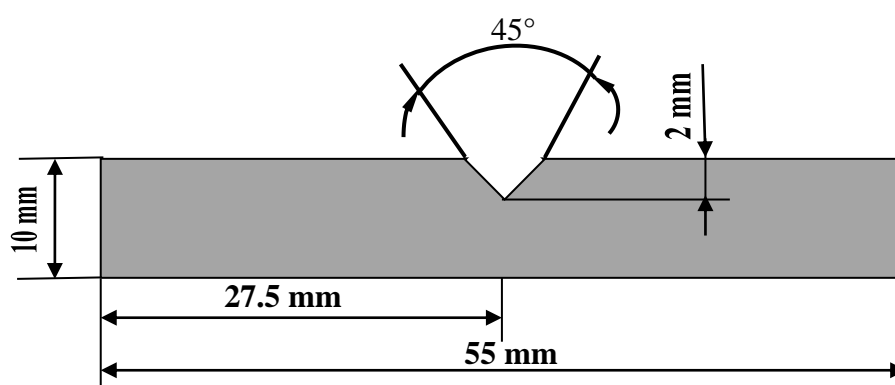

Figure.3. Charpy V specimen.

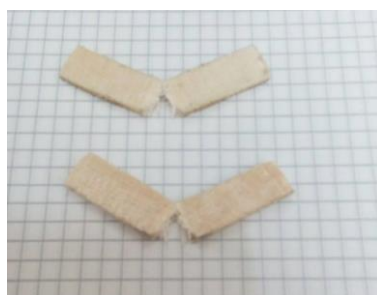

Figure.4. Broken sample.

## 1.2. Scanning electron microscopy

The principle of the scanning electron microscope (SEM) consists of the incidence of a focused beam of monokinetic electrons on the material. [6].

Scanning electron microscopy is performed using the ZEISS EVO MA type microscope.

## 1.3. Hardness Vickers

The measurements are made using a pyramid-shaped diamond indenter with a square base and a top between the face equal to 136 °.

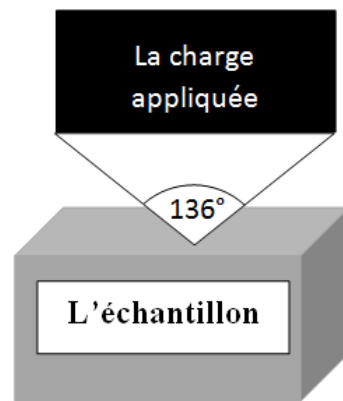

Figure.5. *The indenter for the Vickers test of pyramid shape.*

## 2. Results and discussions

### 2.1. Scanning electron microscopy

The microstructure (figure5) presents a not homogeneous distribution of fibers in the matrix and is characterized by local fluctuations in the fraction of reinforcement.

We notice generally the presence of high-fiber zones and the other rich in matrix.

The thermosetting matrices reinforced by long fibers are heterogeneous materials by nature. To estimate the properties of this type of composites, it is not possible to take into account all these heterogeneities [7].

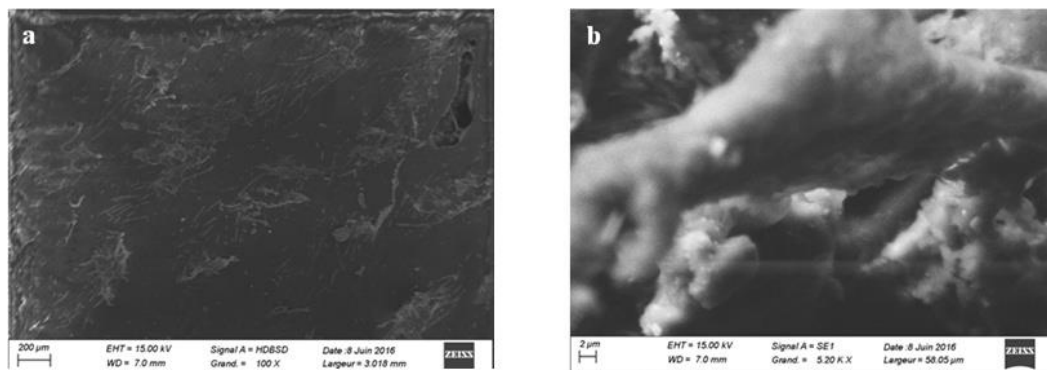

Figure.5. *Photographs taken in scanning electron microscopy of the composite studied. a) Photography with 100X magnification. B) Photography with 5000X magnification.*

### 2.2. Resilience testing

The following tables summarize the results of the impact tests:

The results of energy of impact show that, the energy of impacts decrease with the increase of the temperature, which explains the fragility of the material studied at base temperature.

NB: B is the thickness of the specimen (mm) and W is the width of the specimen (mm).

BWO: is the specimen dimension compliance function, where B and W are the specimen depth and width respectively [3]. The composite was tested by the charpy pendulum at five different points, to do this, five samples (01, 02, 03, 04, 05) were made for each temperature.

**Table.1. Results of the impact test for the specimens with a temperature of 5° C.**

Specimen	Impact energy U(J)	Resilience K <sub>CV</sub> (J/Cm <sup>2</sup> )	Average resilience K <sub>CV</sub> (J/Cm <sup>2</sup> )	shape factor Ø	compliance BWØ (mm <sup>2</sup> )
01	3	7.5	7.53	0.588	29,214
02	3.2	6.4		0.538	30,208
03	3	7.5		0.612	29,107
04	3.4	8.5		0.548	29,476
05	3.1	7.75		0.521	27,556

**Table.2. Results of the impact test for the specimens with a temperature of 15° C.**

Specimen	Impact energy U(J)	Resilience K <sub>CV</sub> (J/Cm <sup>2</sup> )	Average resilience K <sub>CV</sub> (J/Cm <sup>2</sup> )	shape factor Ø	compliance BWØ (mm <sup>2</sup> )
01	2	6.7	6.43	0,740	27,076
02	2.1	7		0,583	23,044
03	2.4	6		0,597	27,151
04	2	6.7		0,475	19,204
05	2.3	5.75		0,591	27,396

**Table.3. Results of the impact test for the specimens with a temperature of 25° C.**

Specimen	Impact energy U (J)	Resilience K <sub>CV</sub> (J/Cm <sup>2</sup> )	Average resilience K <sub>CV</sub> (J/Cm <sup>2</sup> )	shape factor Ø	compliance BWØ (mm <sup>2</sup> )
01	1.6	5.33	5.22	0,554	21,075
02	1.6	5.33		0,617	23,554
03	1.5	3.75		0,659	27,181
04	1.8	6		0,518	21,927
05	1.7	5.7		0,513	21,487

**Table.4. Results of the impact test for the specimens with a temperature of 35° C.**

Specimen	Impact energy U(J)	Resilience $K_{CV}$ (J/Cm <sup>2</sup> )	Average resilience $K_{CV}$ (J/Cm <sup>2</sup> )	shape factor $\emptyset$	compliance BW $\emptyset$ (mm <sup>2</sup> )
01	1.3	3.25	4.45	0,587	24,932
02	1.2	4		0,579	20,112
03	1.4	4.7		0,600	25,261
04	1.4	3.5		0,572	26,788
05	1	3.33		0,602	24,750

**Table.5. Results of the impact test for the specimens with a temperature of 45° C.**

Specimen	Impact energy U(J)	Resilience $K_{CV}$ (J/Cm <sup>2</sup> )	Average resilience $K_{CV}$ (J/Cm <sup>2</sup> )	shape factor $\emptyset$	compliance BW $\emptyset$ (mm <sup>2</sup> )
01	1	3.94	3.94	0,550	19,255
02	1	3.33		0,583	22,631
03	1.3	4.33		0,621	23,673
04	1.2	4		0,553	22,469
05	1.4	4.7		0,667	26,656

The "figure 6" Shows that the value of the resilience decreases with the increase in temperature.

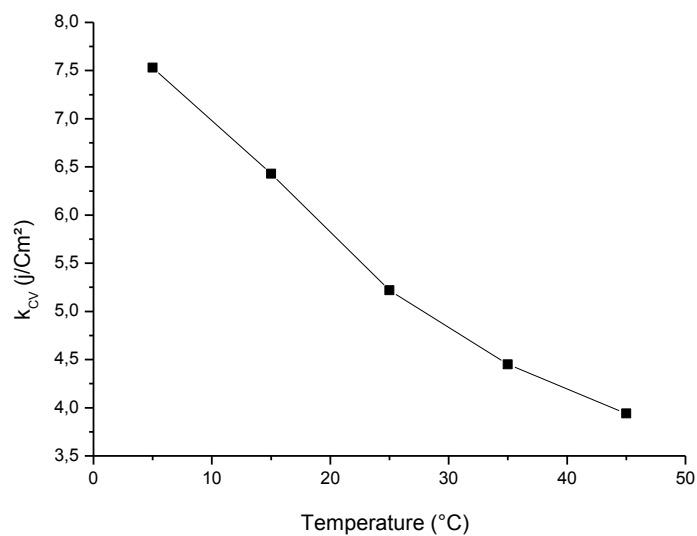

**Figure.6. Evolution of resilience as a function of temperature of specimen.**

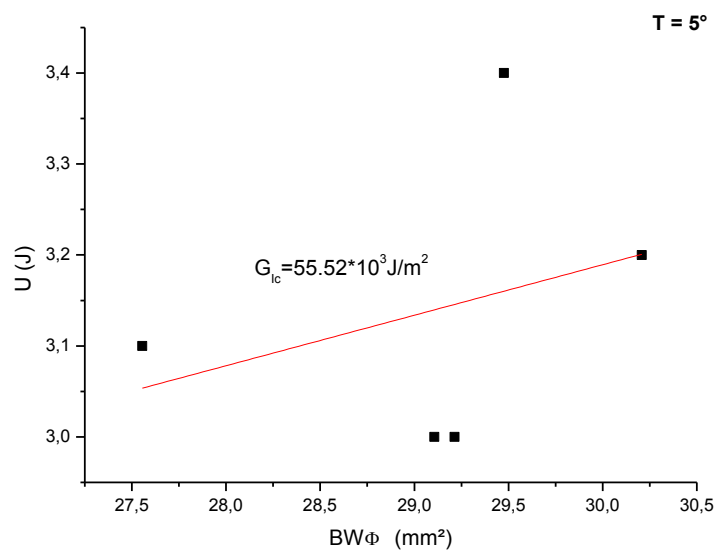

Figure.7. Impact energy as a function of compliance of specimen at  $5^\circ$ .

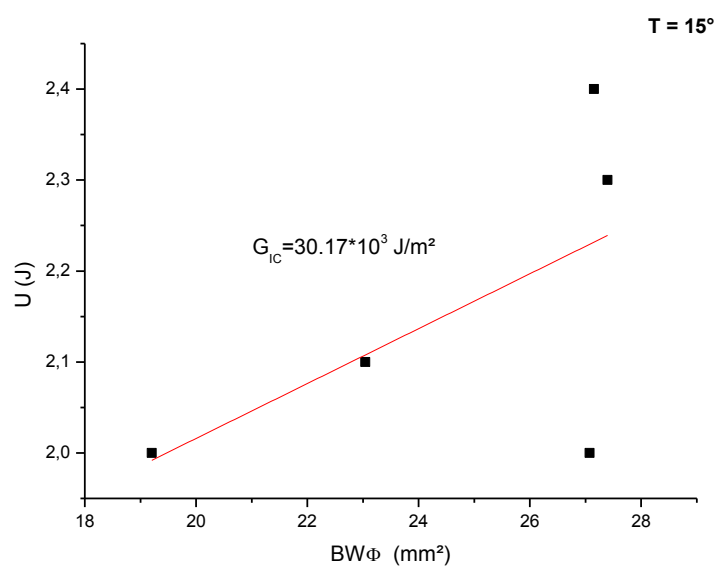

Figure.8. Impact energy as a function of compliance of specimen at  $15^\circ$ .

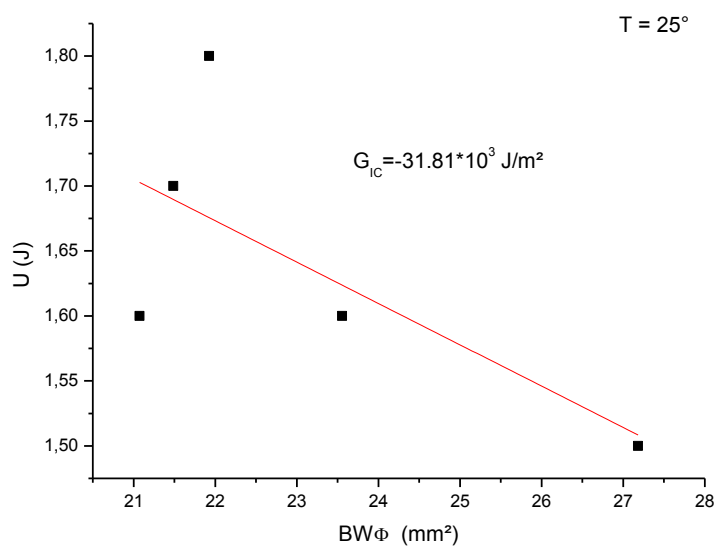

Figure.9. Impact energy as a function of compliance of specimen at 25°.

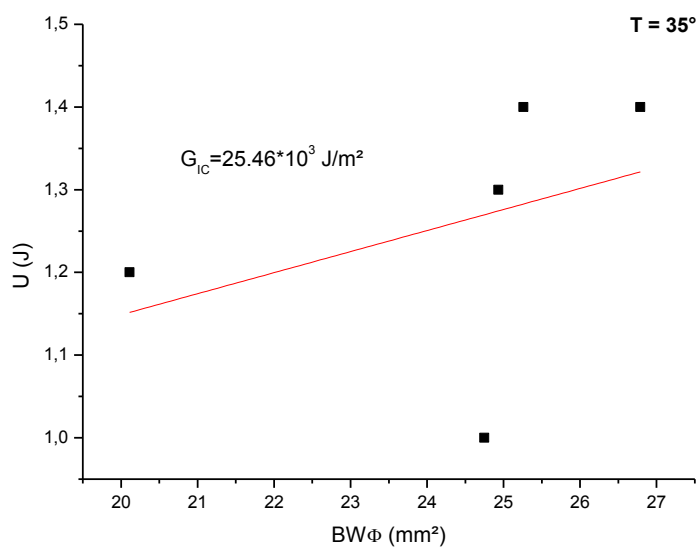
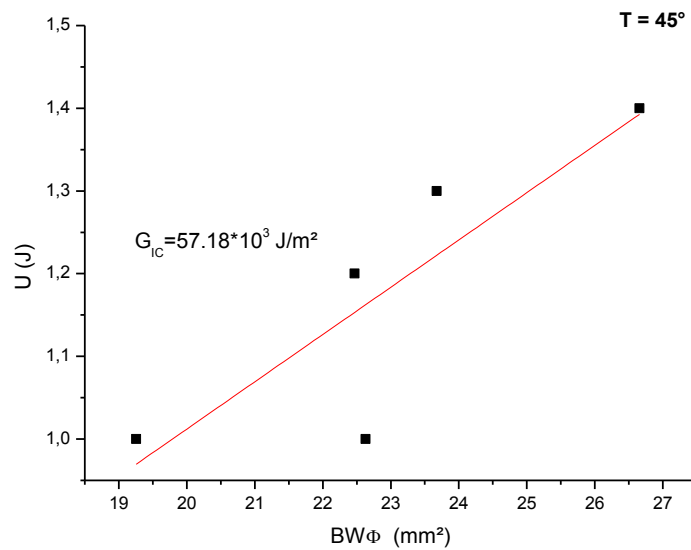

Figure.10. Impact energy as a function of compliance of specimen at 35°.





**Figure.11. Impact energy as a function of compliance of specimen at 45°.**

The slope GIC represents the rate of critical energy recovery of the material studied. U is the energy absorbed by the hammer and  $\Phi$  represents the energy calibration factor, it depends on the notch depth, the dimensions of the specimen and the distance between the supports [3,8].

In materials science, the value of GIC makes it possible to make a very interesting classification for the different usual families. In sum, it is noted that polymeric materials have important values especially when it is known that composites have extended bases in polymers [9]. “The figures 7, 8, 9, 10, 11” Shows the evolution of the absorbed energy according to which the values of the GIC critical energy restitution values of the material studied with different temperatures (5 °, 15 °, 25 °, 35 ° and 45 °). (5 °, 15 °, 25 °, 35 ° and 45 °).

**Table.6. Values whose GIC slope restores critical energy for the specimen at different temperatures.**

temperature of the specimen	5°	15°	25°	35°	45°
Restitution of critical energy G <sub>IC</sub> (KJ/m <sup>2</sup> )	55.52	30.17	-31.81	25.46	57.18

### 2.3. Hardness

The hardness of the fiberglass reinforced composite increases with temperature (figure12), the rate of degradation is not proportional to the temperature but, sometimes, it can be exponentially with the latter [10]. The bio-composites must therefore be used at the lowest possible temperatures [11].

**Table.7. Values of Hardness Vickers for the specimen after different temperatures.**

temperature of the specimen	5°	15°	25°	35°	45°
Value of HV (Kgf/mm <sup>2</sup> )	10.02	10.24	12.06	13.02	15.79

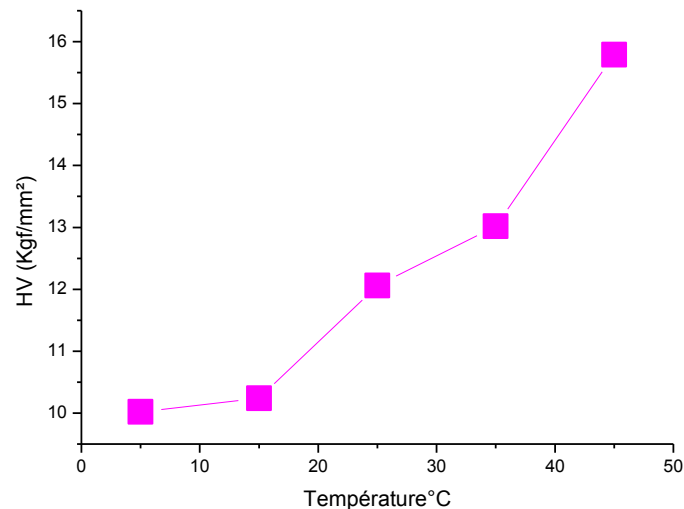
**Figure.12. Variation of hardness as a function of temperature.**

### 3. Conclusion

This study allowed us to study the evolution of the parameters to deduct by the test of impact Charpy as a function of temperature for a composite material intended for the orthopedic prosthesis of a tibia consisting of a polymer matrix reinforced with a glass fiber. The heterogeneity observed by scanning electron microscopy of the composite studied did not allow us to obtain a material in the desired properties. For this purpose, the critical energy restitution values of which the GIC slope which represents the maximum resistance to shocks vary from one temperature to another in an irregular manner. Moreover, the impact resistance decreases with increasing temperature, which shows the ductility of the material studied with the increase in temperature. Moreover, the hardness increases with increasing temperature, which explains that, the increase in temperature favors the fragile behavior of the composite studied.

### Références

- [1] J. Aucher, Etude comparative du comportement de composites à matrice thermoplastique ou thermodurcissab, Thèse, Institut National des Sciences Appliquées de Rouen, 2009.
- [2] M.A.Mbacke. Caractérisation et modélisation du comportement mécanique des composites tressés 3D : Application à la conception de réservoirs GNV, Thèse, Université de Paristech, 2013.
- [3] J. Niglia, A. Cisilino, R. Seltzer, P. Frontini, Determination of impact fracture toughness of polyethylene using arc-shaped specimens, Engineering Fracture Mechanics 69 (2002) 1391–1399.

- [4] E.Plati and J. G. Williams, The Determination of the Fracture Parameters for Polymers in Impact, polymer engineering and science, june, 1975, Vol. 15, No. 6.
- [5] Roger Brown, Handbook of Polymer Testing / Short-Term Mechanical Tests, Rapra Technology Limited, ISBN: 1-85957-324-X, 2002.
- [6] Ismahane KEBBACHE, Caractérisation microstructurale et cristallographique des alliages a base de cuivre élaborés par procédé HF, Thèse, Université Badji Mokhtar, ANNABA, 2011.
- [7] L. Skrivars, M. Berglund, F.Ericson, Microscopy of the morphology in low styrene emission glass fibre/unsaturated polyester laminates, Journal of Applied Polymer Science, 71 (1999) 1555-1562.
- [8] Y.Djebloun, Chapitre III : Mécanique linéaire élastique de la rupture, seThè, Université de Biskra ,Algérie, 2004.
- [9] D.R. Moore, A. Pavan and J.G. Williams, Fracture mechanics testing methods for polymers adhesives and composites, Elsevier Science Ltd, 2001.
- [10] M.Robert, P.Cousin, B.Benmokrane, Influence de la température sur le comportement des composites de PRF pour le génie civil, Annales du BTP, 6 (2008) 21-27.
- [11] Glossaire des matériaux composites, CARMA, Actualisation octobre 2006.